

# TEV-3110-60

## The Energy saving Ventilator



### ENERGY CONSERVATION

PlymoVent's mission is to design energy efficient products. PlymoVent utilizes as standard equipment Energy Efficient Motors. This standard in conjunction with our new design produces the lowest operating cost fan package offered in the world today. If you have an existing fan, you can replace it with a PlymoVent and reduce your operating costs and in turn receive a return on your investment. Not many other products can stand behind that claim.

### POWER CONSUMPTION

PlymoVent fans require less kW versus air volume delivered. This does not only equate to less power consumption but also less installation cost. This allows the electrical installer to reduce the cost of installation by reducing the associated components required to run the motor.

### EASY ACCESS IMPELLER

All PlymoVent fan housings are designed for easy access to the impeller. Our design allows an installer or service technician to remove the motor and impeller wheel without removing inlet or outlet ductwork or disassembling the fan housing. It also provides the installer the option of separating the fan into two pieces when mounting in confined locations above drop ceilings or tight access ways.

### AIRFOIL IMPELLER

PlymoVent in co-operation with an internationally recognized university, has designed the ultimate airfoil fan impeller. Through the use of aerospace design techniques, PlymoVent has been successful in designing a fan impeller that maximizes air delivery at higher static pressures and reduces energy consumption at the same time. PlymoVent fans deliver the air volume you need at 30% less energy required over any competitive fan.



www.PacAir.net



**PLYMOVENT**<sup>®</sup>  
INTELLIGENT PROCESS VENTILATION™

PlymoVent reserves the right to make design and technical changes.

	mm	inches
A	640	25 3/16
B	640	25 3/16
C	230	9 1/16
D	200	7 7/8
E	160	6 5/16
F	254	10
G	472	18 19/16
H	355	13 31/32

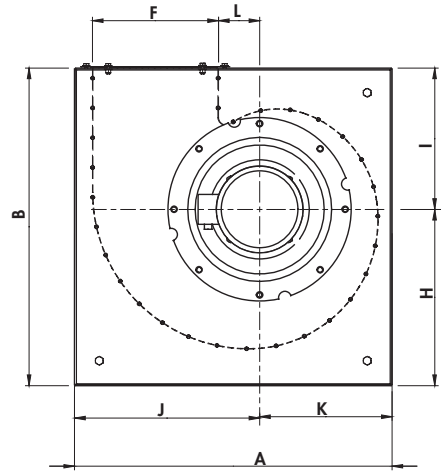
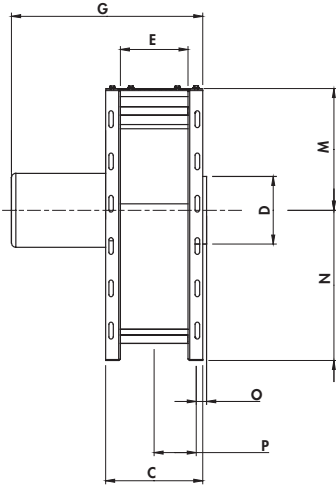

	mm	inches
I	288	11 11/32
J	373	14 11/16
K	267	10 1/2
L	83	3 9/32
M	288	11 11/32
N	355	13 31/32
O	25	1
P	99	3 15/16

**TECHNICAL DATA**

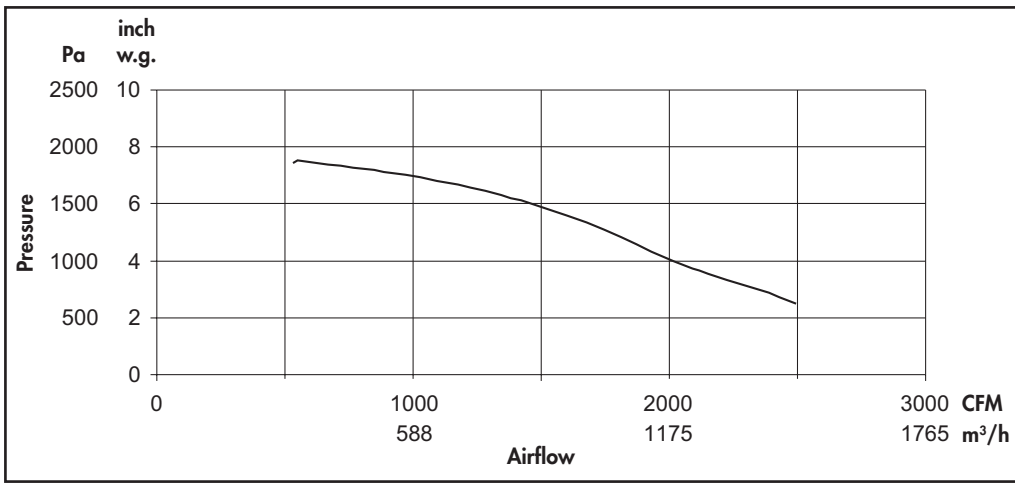

**Motor specifications**

- Frame size: G 56HC
- Shaft size: 5/8 inch
- Motor: 3.0 HP
- Motor RPM: 3450 rpm
- Service factor: 1.15
- Thermal protection: No
- CSA: Yes
- CE-listed: Yes

*Electrical power is available for all international electrical power sources.*

Data based on AMCA testing in accordance with AMCA Standard 210.

**Fan specifications**

- Construction: AMCA Type - B
- Drive type: Direct drive
- Impeller type: Backward incline
- Impeller material: Aluminum
- Impeller diameter: 315 mm / 12.4 inch
- Impeller width: 110 mm / 4.33 inch
- Hub size: 16 mm / 5/8 inch
- Discharge style: Rotational 90°
- Shaft seal: Rubber
- Housing material: Galvanized steel
- Housing finish: Epoxy powder coat
- Total fan weight: 39 kg / 85 lbs

**SOUND POWER DATA**

Speed	Pressure in wg	Octave Band (Hz)								LwA
		63 Hz	125 Hz	250 Hz	500 Hz	1000 Hz	2000 Hz	4000 Hz	8000 Hz	
3500	0	98.9 dB	42.4 dB	70.5 dB	96.5 dB	90.7 dB	86.1 dB	82.8 dB	77.8 dB	96.3 dB
3500	1	99.6 dB	84.1 dB	90.2 dB	96.2 dB	89.6 dB	85.2 dB	81.7 dB	76.9 dB	95.8 dB
3500	2	99.9 dB	103.6 dB	99.1 dB	96.0 dB	89.2 dB	84.6 dB	80.5 dB	75.7 dB	97.2 dB
3500	3	99.9 dB	103.6 dB	98.7 dB	96.0 dB	89.3 dB	84.1 dB	79.4 dB	74.4 dB	97.0 dB
3500	4	101.3 dB	104.5 dB	98.9 dB	95.7 dB	88.7 dB	83.4 dB	78.7 dB	73.7 dB	96.9 dB

Data based on AMCA testing in accordance with AMCA Standard 300.



**Pacific Air Consultants, Inc.**

P.O. Box 426 - 33100 NE Ivy Avenue  
 La Center, Washington 98629 USA  
 Ph. (800) 252-3993 - Fax (360) 263-9772  
 web- PacAir.net - Email- Sales@PacAir.net