

TEV-585-60

The Energy saving Ventilator



EASY ACCESS IMPELLER

All PlymoVent fan housings are designed for easy access to the impeller. Our design allows an installer or service technician to remove the motor and impeller wheel without removing inlet or outlet ductwork or disassembling the fan housing. It also provides the installer the option of separating the fan into two pieces when mounting in confined locations above drop ceilings or tight access ways.

AIRFOIL IMPELLER

PlymoVent in co-operation with an internationally recognized university, has designed the ultimate airfoil fan impeller. Through the use of aerospace design techniques, PlymoVent has been successful in designing a fan impeller that maximizes air delivery at higher static pressures and reduces energy consumption at the same time. PlymoVent fans deliver the air volume you need at 30% less energy required over any competitive fan.

ENERGY CONSERVATION

PlymoVent's mission is to design energy efficient products. PlymoVent utilizes as standard equipment Energy Efficient Motors. This standard in conjunction with our new design produces the lowest operating cost fan package offered in the world today. If you have an existing fan, you can replace it with a PlymoVent and reduce your operating costs and in turn receive a return on your investment. Not many other products can stand behind that claim.

POWER CONSUMPTION

PlymoVent fans require less kW versus air volume delivered. This does not only equate to less power consumption but also less installation cost. This allows the electrical installer to reduce the cost of installation by reducing the associated components required to run the motor.



www.PacAir.net



PLYMOVENT[®]
INTELLIGENT PROCESS VENTILATION™

PlymoVent reserves the right to make design and technical changes.

	mm	inches
A	785	30 29/32
B	785	30 29/32
C	270	10 5/8
D	250	9 27/32
E	200	7 7/8
F	322	12 11/16
G	542	21 11/32
H	444	17 15/32
I	341	13 7/16

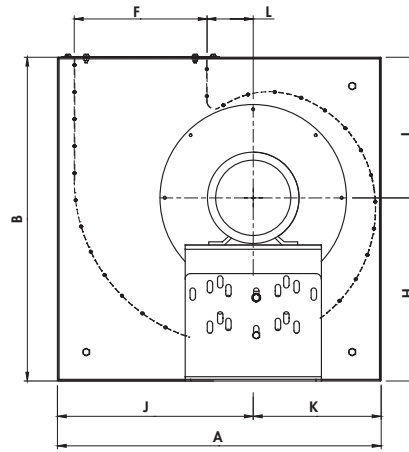
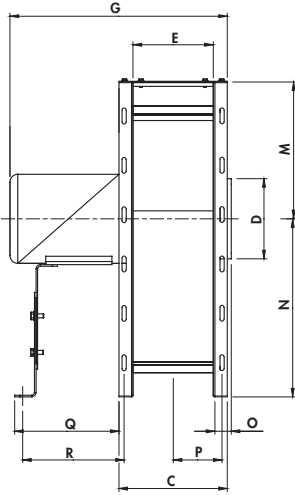

	mm	inches
J	475	18 11/16
K	310	12 7/32
L	112	4 13/32
M	341	13 7/16
N	444	17 15/32
O	25	1
P	119	4 13/32
Q	253	9 31/32
R	261	10 1/4

TECHNICAL DATA

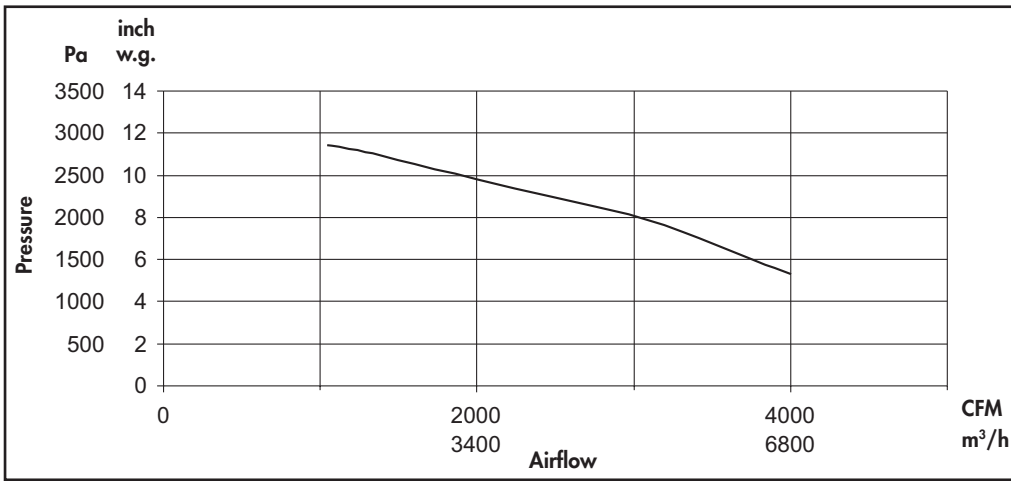

Motor specifications

- Frame size: NXS213TC
- Shaft size: 1 3/8 inch
- Motor: 7.5 HP
- Motor RPM: 3450 rpm
- Service factor: 1.15
- Thermal protection: No
- CSA: Yes
- CE-listed: Yes

Electrical power is available for all international electrical power sources.

Data based on AMCA testing in accordance with AMCA Standard 210.

Fan specifications

- | | | |
|---------------------------------|---------------------------------------|------------------------------------|
| Construction: AMCA Type - B | Impeller diameter: 415 mm / 16.3 inch | Shaft seal: Rubber |
| Drive type: Direct drive | Impeller width: 85 mm / 3.35 inch | Housing material: Galvanized steel |
| Impeller type: Backward incline | Hub size: 35 mm / 1 3/8 inch | Housing finish: Epoxy powder coat |
| Impeller material: Aluminum | Discharge style: Rotational 90° | Total fan weight: 84 kg / 185 lbs |

SOUND POWER DATA

Speed	Pressure in wg	Octave Band (Hz)								LwA
		63 Hz	125 Hz	250 Hz	500 Hz	1000 Hz	2000 Hz	4000 Hz	8000 Hz	
3500	0	103.9 dB	106.9 dB	109.2 dB	106.2 dB	97.4 dB	93.2 dB	89.1 dB	83.8 dB	106.4 dB
3500	1	103.9 dB	106.9 dB	108.5 dB	105.5 dB	96.9 dB	92.3 dB	88.2 dB	82.8 dB	105.7 dB
3500	2	103.9 dB	106.9 dB	107.8 dB	104.7 dB	96.4 dB	91.5 dB	87.2 dB	81.8 dB	105.0 dB
3500	3	103.9 dB	106.9 dB	107.5 dB	104.2 dB	96.0 dB	91.0 dB	86.7 dB	81.3 dB	104.6 dB
3500	4	103.9 dB	106.9 dB	107.2 dB	103.8 dB	95.5 dB	90.5 dB	86.2 dB	80.8 dB	104.2 dB
3500	5	103.5 dB	106.5 dB	106.4 dB	102.9 dB	94.3 dB	89.3 dB	84.9 dB	79.8 dB	103.3 dB

Data based on AMCA testing in accordance with AMCA Standard 300.



Pacific Air Consultants, Inc.

P.O. Box 426 - 33100 NE Ivy Avenue
 La Center, Washington 98629 USA
 Ph. (800) 252-3993 - Fax (360) 263-9772
 web- PacAir.net - Email- Sales@PacAir.net